

# MuYu

## MY-BT304B

Bluetooth 5.4 LE Audio Module

Version 1.0

### Contact Us

Shenzhen Muyu Technology Co., Ltd

Email: [info@muyusmart.com](mailto:info@muyusmart.com)

Zipcode: 518100

Web: [www.muyumodule.com](http://www.muyumodule.com)

## Release Recode

Version	Date	Comments
1.0	2023/06/01	Initial Version

Shenzhen Muyu Technology Co., Ltd

## Content

<b>1</b>	<b>Introduction</b> .....	4
<b>1.1</b>	<b>Overview</b> .....	4
<b>1.2</b>	<b>Feature:</b> .....	4
<b>1.3</b>	<b>Applications</b> .....	6
<b>1.4</b>	<b>Key Features</b> .....	6
<b>2</b>	<b>Electrical Characteristic</b> .....	7
<b>3</b>	<b>Schematic Block diagram</b> .....	7
<b>4</b>	<b>Mechanical Dimensions</b> .....	8
<b>5</b>	<b>Pin Definition Descriptions</b> .....	9
<b>6</b>	<b>Peripheral reference schematic</b> .....	12
<b>7</b>	<b>SMT reference</b> .....	15

# 1 Introduction

## 1.1 Overview

MY-BT304C is a data + audio Bluetooth 5.4 module. Uses Qualcomm QCC3084 chip solution, supports analog audio, support SBC、LC3、AAC、APTX、APTX-HD、APTX Adaptive、APTX Lossless...audio codecs, and supports multiple functions and protocols such as BLE, SPP, AVRCP, I<sup>2</sup>S, SPDIF, etc.

MY-BT304B uses UART as a programming interface, and customers can use AT commands to read or write the configuration of the module through UART. And also support IO function. Can provide more possibilities for customers' applications.

## 1.2 Feature:

- Qualified to Bluetooth v5.4 specification
- Quad-core processor architecture
- High-performance Bluetooth® stereo audio SoC
- Flexible flash programmable platform
- Low power modes to extend battery life
- SBC, LC3, AAC, APTX, APTX-HD, APTX Adaptive, APTX Lossless...audio codecs
- Transfer port: PIO, UART, USB, I2C, SPI, AIO, LED
- Audio output port: I2S, SPDIF, ANALOG
- Audio input port: I2S, SPDIF, USB, AUX, MIC
- dual mode, The traditional Bluetooth and BLE
- Integrated 16-64MB SPI Flash
- Low power consumption
- High SNR class AB or class D analog output is optional
- 240 MHz Qualcomm® Kalimba™ audio DSPs
- 32/80 MHz Developer Processor for applications
- Firmware Processor for system
- Flexible QSPI flash programmable platform
- High-performance 24-bit stereo audio interface
- Digital and analog microphone interfaces
- Flexible LED controller and LED pins with PWM support
- Serial interfaces: UART, Bit Serializer (I<sup>2</sup>C/SPI), USB 2.0
- Advanced audio algorithms
- Active Noise Cancellation: Hybrid, Feedforward, and Feedback modes, using Digital or Analog Mics, enabled using license keys available from Qualcomm®

- Qualcomm® aptX™ and aptX-HD Audio
- aptX Adaptive, enabled using license key
- Qualcomm® cVc™ Noise Cancellation Technology, enabled using license key
- Integrated PMU: Dual SMPS for system/digital circuits, Integrated Li-ion battery charger
- Small size: 20\*13\*2.0mm
- RoHS compliant

## Audio subsystem

- Dual 32-bit Kalimba audio digital signal processor (or processing) (DSP) cores with flexible clocking from 2 MHz to 240 MHz to enable optimization of performance vs. power consumption
- DSPs execute code from ROM and from program RAM
- OEM and third party developed features can execute from program RAM
- 384 KB program RAM
- 1408 KB data RAM

## Application subsystem

- Dual-core application subsystem 32/80 MHz operation
- 32-bit Firmware Processor (reserved for system use) executes:
  - Bluetooth upper stack
  - Profiles
  - House-keeping code
- 32-bit Developer Processor executes: Developer applications
- Both cores execute code from external flash memory using QSPI clocked at 32 MHz or 80 MHz
- On-chip caches per core enable optimized performance and power consumption

## Bluetooth subsystem

- Qualified to Bluetooth v5.4 specification including 2 Mbps Bluetooth Low Energy and Bluetooth Low Energy Isochronous Channels
- Qualcomm® Bluetooth High Speed Link
- Single ended antenna connection with on-chip balun and Tx/Rx switch
- Bluetooth, Bluetooth Low Energy, and mixed topologies supported
- Class 1 support

## Power management

- Integrated power management unit (PMU) to minimize external components
- QCC5181 WLCSF runs directly from a Li-ion, USB, or external supply (2.8 V to 6.5 V)
- Auto-switching between battery and USB (or other) charging source
- Power islands employed to optimize power consumption for variety of use-cases
- Dual switch-mode power supply (SMPS):
  - Automatic mode selection to minimize power consumption

1.8 V SMPS generates power for both the device and off-chip circuits

Dedicated digital SMPS (output voltage changes automatically to minimize device power consumption)

### 1.3 Applications

- High-End Stereo Wireless Headsets
- High-END Mono Headsets
- Hands-Free Car Kits
- Bluetooth-Enabled Automotive Dashboards
- Wired/wireless stereo headsets/headphones
- Qualcomm TrueWireless™ stereo earbuds

### 1.4 Key Features

Operating Frequency Band	2.402GHz -2.480GHz ISM band
Bluetooth Specification	V5.4
Theoretical range in open field	Bluetooth Class 1
Main Chip	QCC3084
Transmitter Power	+15dBm (Typical)
Receive Sensitivity	-97dB at 0.1% BER (Typical)
Antenna	External
Antenna Impedance	50Ω
Power Supply	2.8V-4.3V
Dimension	20mm(L) * 13mm(W) * 2.0mm(H)

## 2 Electrical Characteristic

Rating	Min	Typ	Max	Unit
Store temperature	-40	+20	+85	°C
Operation temperature	-20	+20	+70	°C
Power supply (VBAT)	3.0	3.6	4.3	V
USB_5V, Charge input	4.5	5	5.5	V
PIO Power supply (VDD_PAD13/VDD_PAD6)	1.8	3.3	3.6	V

## 3 Schematic Block diagram

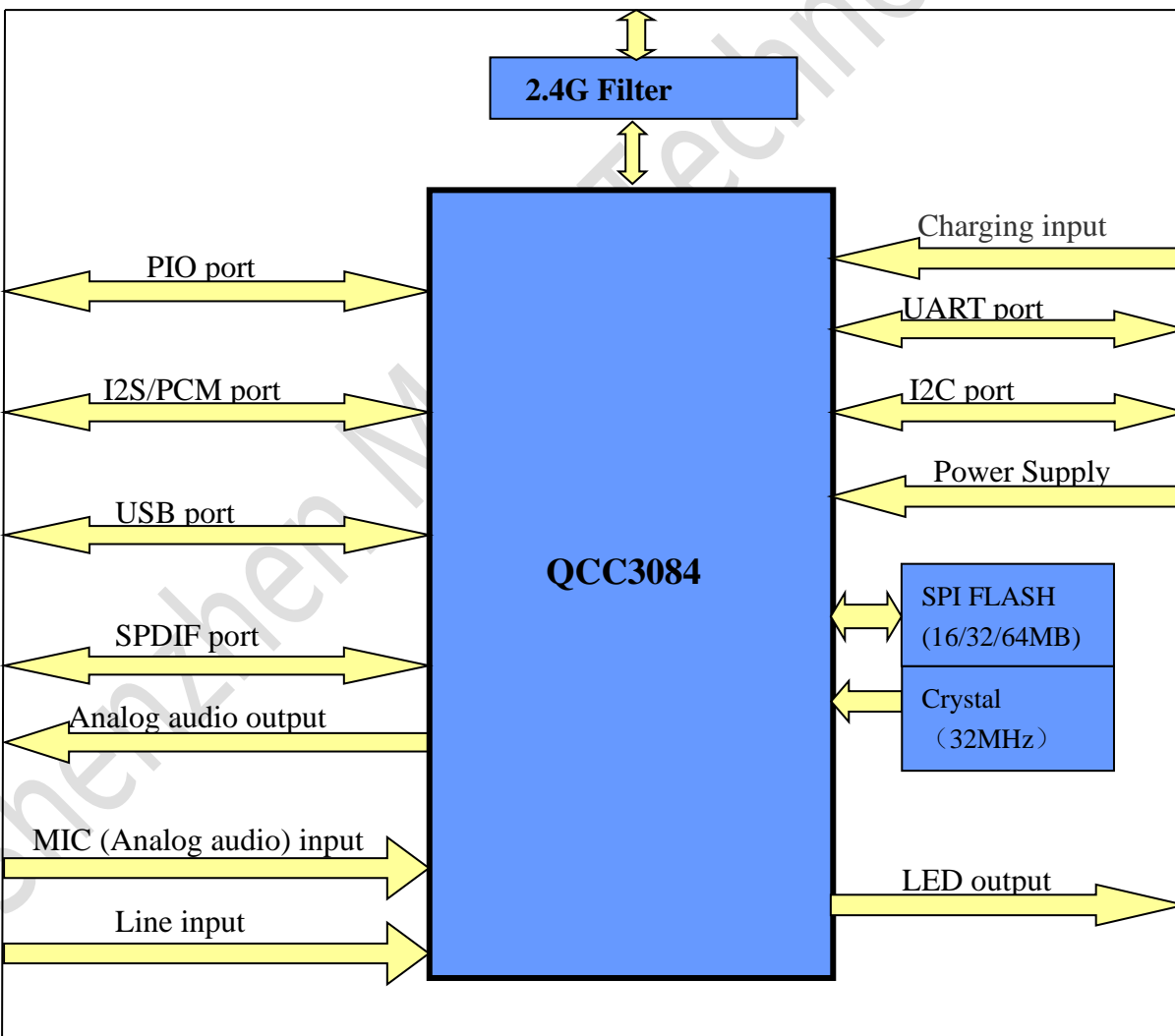

## 4 Mechanical Dimensions

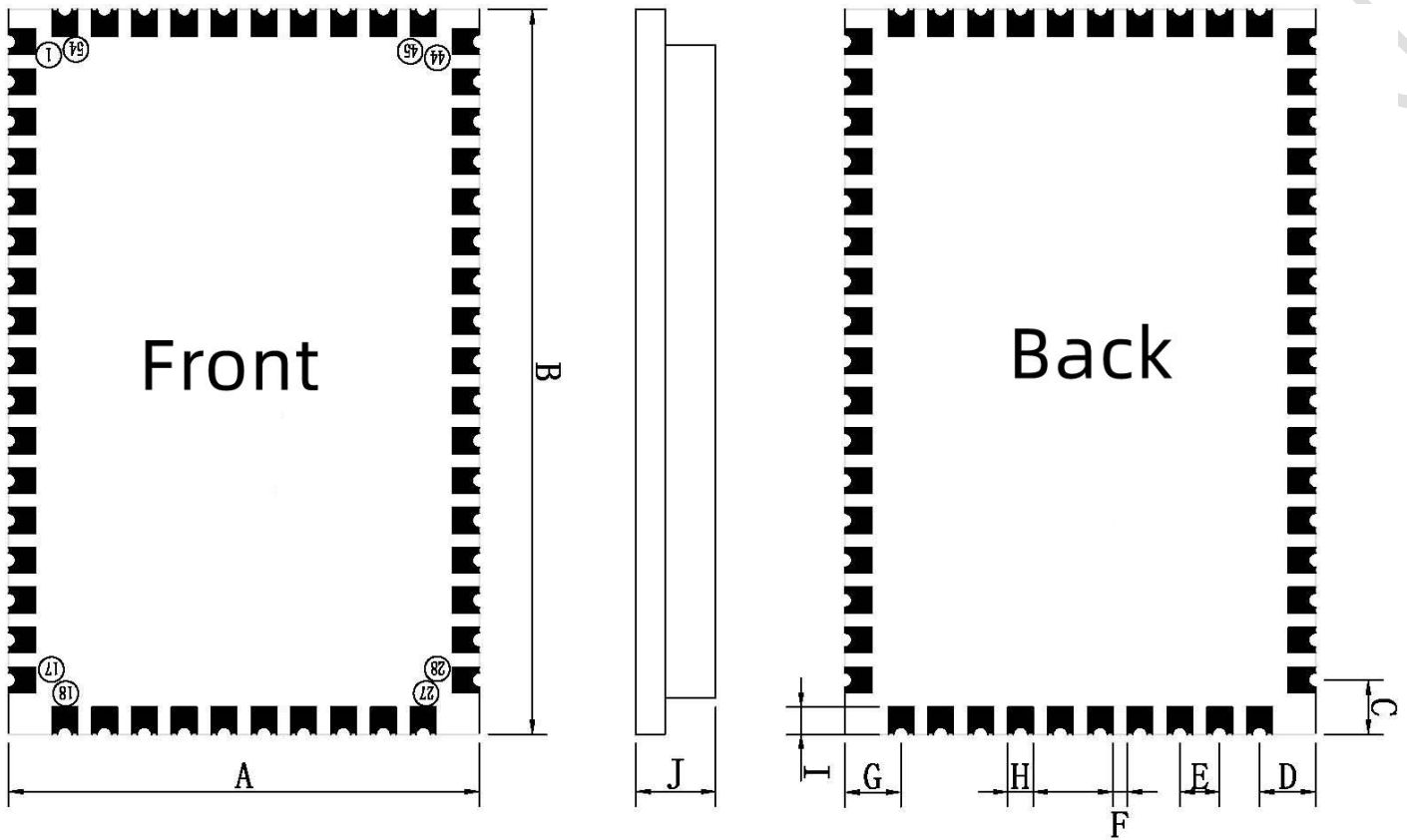

Dimension Limits (Units:mm)		
Symbol	Value	Error
A	13.0	±0.2
B	20.0	±0.2
C	1.5	±0.1
D	1.55	±0.1
E	1.1	—
F	0.4	—
G	1.55	±0.1
H	0.7	—
I	0.75	±0.05
J	2.2	Max



## 5 Pin Definition Descriptions

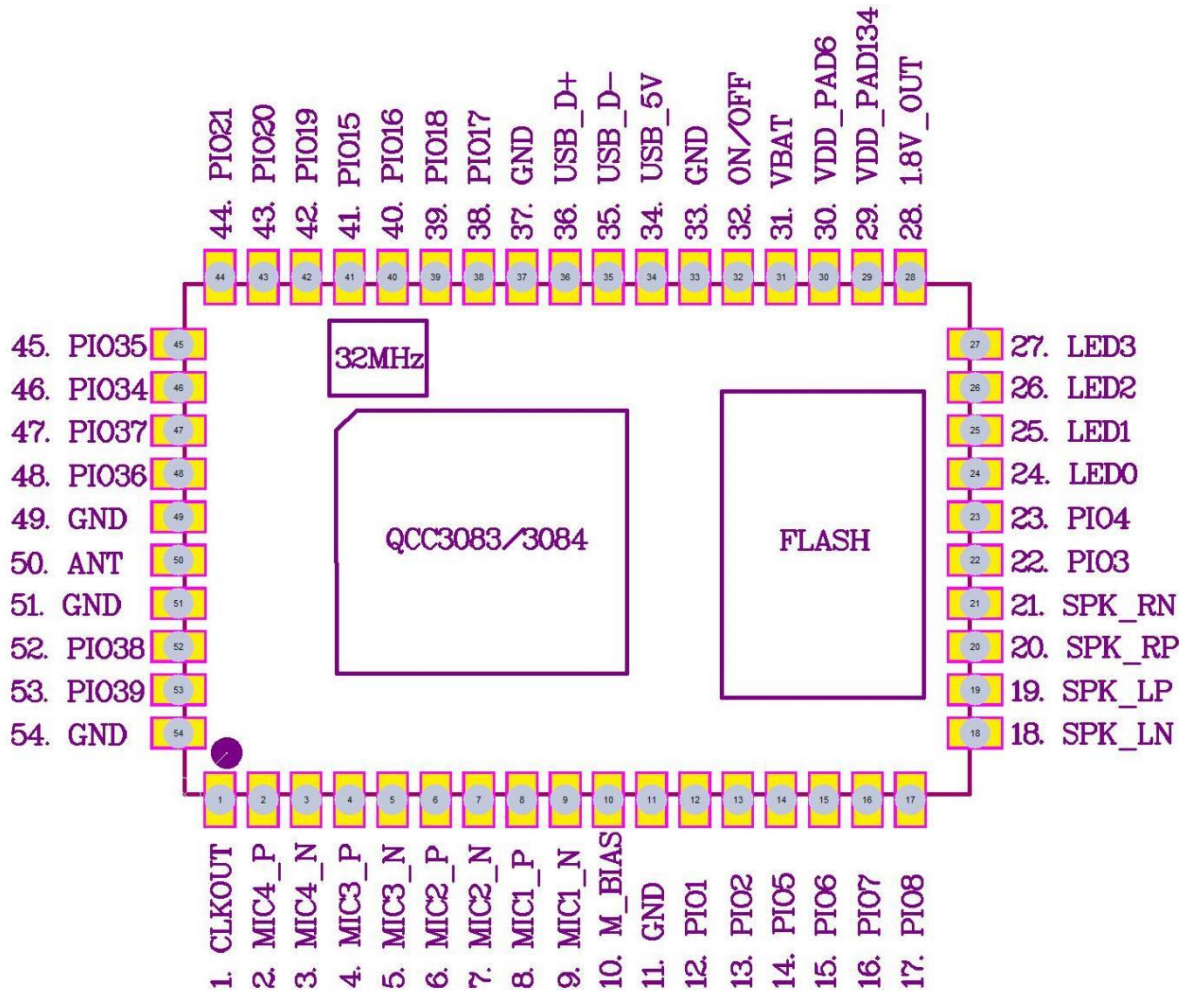

Pin NO.	Pin Name	Supply voltage	Pin Descriptions
1	CLKOUT	VDD_XTAL_1V8	Buffered clock output
2	MIC4_P	VDD_AUDIO_1V8	Microphone differential 4 input, positive Differential audio line input 4, positive
3	MIC4_N	VDD_AUDIO_1V8	Microphone differential 4 input, negative Differential audio line input 4, negative
4	MIC3_P	VDD_AUDIO_1V8	Microphone differential 3 input, positive Differential audio line input 3, positive
5	MIC3_N	VDD_AUDIO_1V8	Microphone differential 3 input, negative Differential audio line input 3, negative
6	MIC2_P	VDD_AUDIO_1V8	Microphone differential 2 input, positive Differential audio line input 2, positive
7	MIC2_N	VDD_AUDIO_1V8	Microphone differential 2 input, negative

			Differential audio line input 2, negative
8	MIC1_P	VDD_AUDIO_1V8	Microphone differential 1 input, positive Differential audio line input 1, positive
9	MIC1_N	VDD_AUDIO_1V8	Microphone differential 1 input, negative Differential audio line input 1, negative
10	MIC_BIAS		Microphone bias
11	GND	0	Ground
12	RESET/PIO1	VDD_PAD1/3	Automatically defaults to RESET# mode when the device is unpowered, or in off modes. Reconfigurable as a PIO after boot.
13	PIO2	VDD_PAD1/3	Programmable input/output line
14	PIO5	VDD_PAD1/3	Programmable input/output line
15	TRB_MOSI PIO6	VDD_PAD1/3	TRB SPI port, TRB_MOSI
16	TRB_MISO /PIO7	VDD_PAD1/3	TRB SPI port, TRB_MISO
17	TRB_CLK /PIO8	VDD_PAD1/3	TRB SPI port, TRB_CLK
18	SPK_LN		Headphone/ Speaker output left negative Differential line output 1, negative
19	SPK_LP		Headphone/ Speaker output left positive Differential line output 1, positive
20	SPK_RP		Headphone/ Speaker output right positive Differential line output 2, positive
21	SPK_RN		Headphone/ Speaker output right negative Differential line output 2, negative
22	PIO3	VDD_PAD1/3	Programmable input/output line
23	PIO4	VDD_PAD1/3	Programmable input/output line
24	LED0/AIO0		LED0/AIO0, General-purpose analog/digital input or open drain LED output
25	LED1/AIO1		LED1/AIO1, General-purpose analog/digital input or open drain LED output
26	LED2/AIO2		LED2/AIO2, General-purpose analog/digital input or open drain LED output
27	LED3/AIO3		LED3/AIO3, General-purpose analog/digital input or open drain LED output
28	1.8V_OUT	1.8V	Internal 1.8V output
29	VDD_PAD1/3	1.8V/3.3V	PIO power supply (PIO1-8), (PIO15-21), 1.8 V/3.3 V PIO supply
30	VDD_PAD6	1.8V/3.3V	PIO power supply (PIO34-39) 1.8 V/3.3 V PIO supply

31	VBAT	2.8-4.3V	Battery voltage input, 3.3V input(typical)
32	ON/OFF(SYS_CTRL)	VBAT	Regulator enable input, boot pin
33	GND	0	Ground
34	USB_5V	5V	Charger input, 5V input
35	USB_DN		USB data minus
36	USB_DP		USB data plus
37	GND	0	Ground
38	I2S_LRCK (PIO17)	VDD_PAD1/3	I2S_LRCK, Programmable input/output line
39	I2S_DOUT (PIO18)	VDD_PAD1/3	I2S_DOUT, Programmable input/output line
40	I2S_BCLK (PIO16)	VDD_PAD1/3	I2S_BCLK, Programmable input/output line
41	I2S_MCLK (PIO15)	VDD_PAD1/3	I2S_MCLK, Programmable input/output line
42	I2S_IN (PIO19)	VDD_PAD1/3	I2S_IN, Programmable input/output line
43	PIO20	VDD_PAD1/3	SPDIF_OUT, Programmable input/output line
44	PIO21	VDD_PAD1/3	Programmable input/output line
45	PIO35	VDD_PAD6	Programmable input/output line
46	PIO34	VDD_PAD6	Programmable input/output line
47	PIO37	VDD_PAD6	Programmable input/output line
48	PIO36	VDD_PAD6	Programmable input/output line
49	GND	0	Ground
50	ANT(BT_RF)		RF port, antenna, Bluetooth transmit/receive
51	GND	0	Ground
52	PIO38	VDD_PAD6	Programmable input/output line
53	PIO39	VDD_PAD6	Programmable input/output line
54	GND	0	Ground

# 6 Peripheral reference schematic

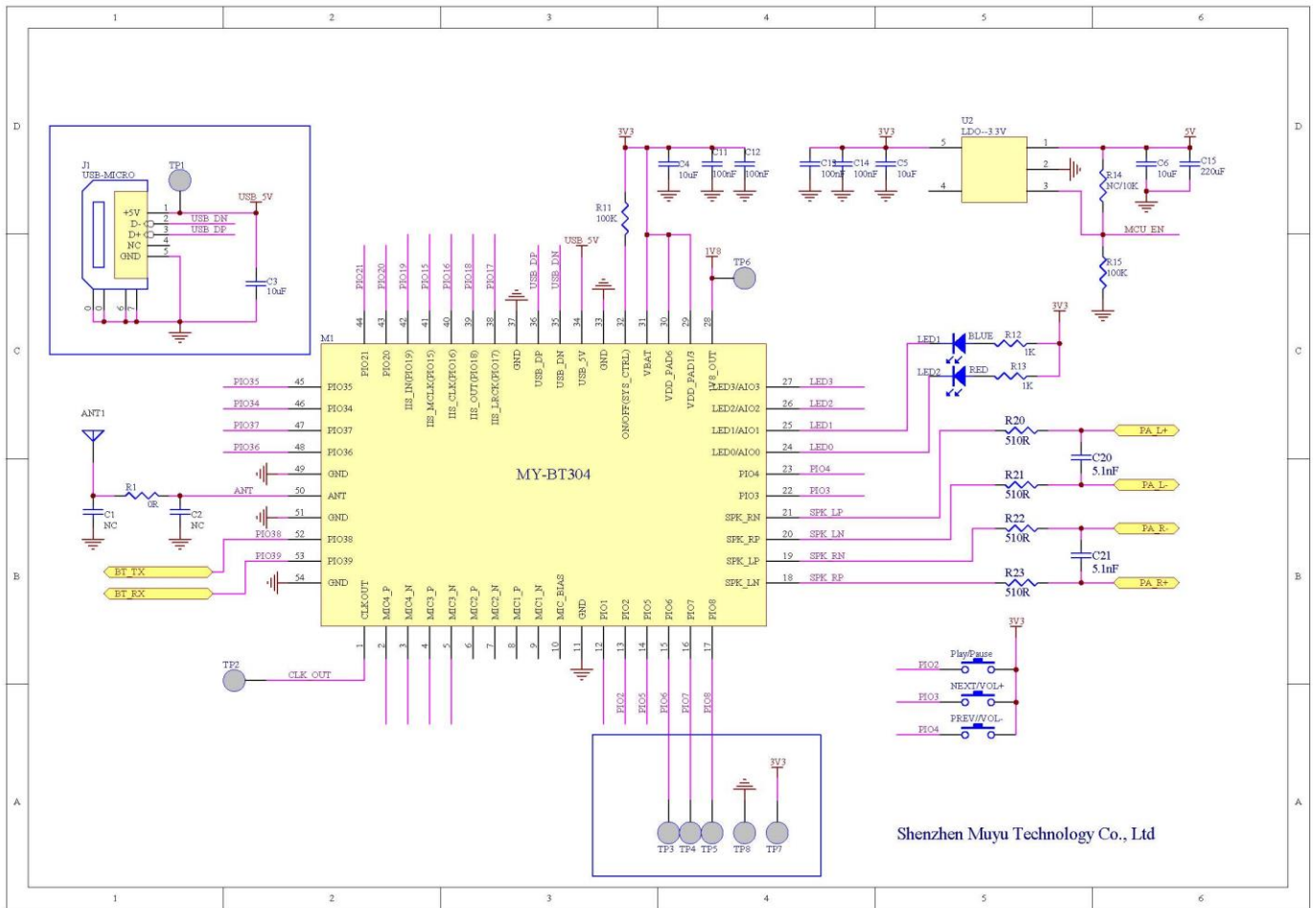

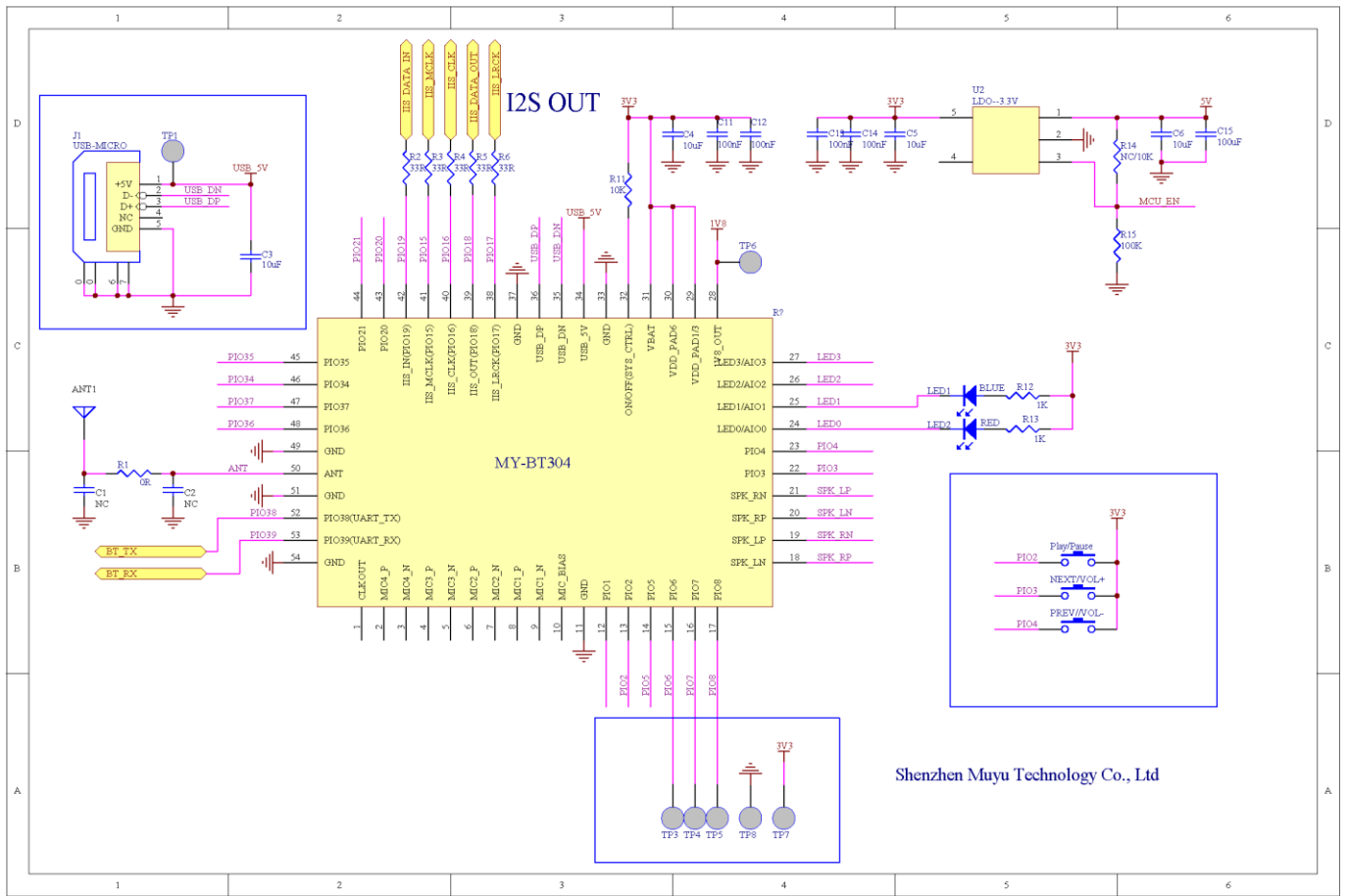

Shenzhen Muyu Technology Co., Ltd

Shenzhen Muyu Technology Co., Ltd

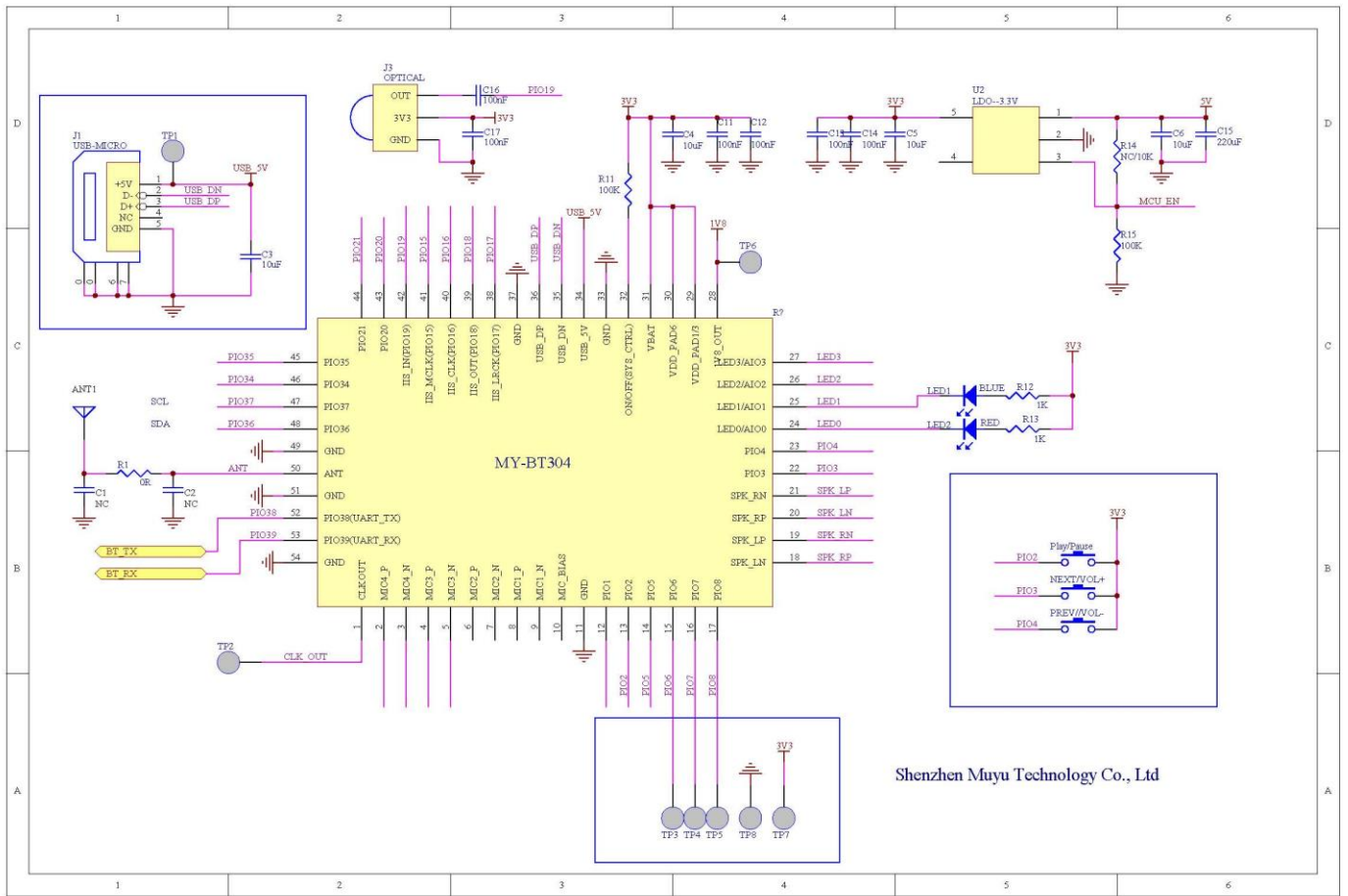

Shenzhen Muyu Technology Co., Ltd

Shenzhen Muyu

## 7 SMT reference

